

Elmdene International Ltd
3 Keel Close, Interchange Park,
Portsmouth, Hampshire, PO3 5QD, UK

Tel: +44(0)23 9269 6638
Fax: +44(0)23 9266 0483
Web: www.elmdene.co.uk

27.6V dc 5A Switch Mode Power Supply for Fire, Access and General Applications

STX2405-MOD

FEATURES

The STX2405-MOD is an un-boxed switch mode power supply ideal for use in Fire, Access Control and General Applications. Its regulated 27.6V dc output will supply up to 5 Amps continuously into the load, in addition to providing up to 850mA for charging the standby batteries up to 17Ah. The power supply output features electronic short circuit protection under both mains and standby battery operation. Maximum battery life is assured through continuous active battery monitoring and the use of a two stage charger, comprising bulk and temperature compensated final float phase depending upon battery condition. Once fully charged the product operates in Eco power saving mode, whereby the batteries are charged for 4 hours in every 24 hour period while still being continuously monitored. This reduces wasted energy in charging already fully charged batteries and extends their working life. Deep discharge protection prevents premature battery failure when operating from standby for extended periods. Two sets of volt free solid state relay fault output, signal (i) loss of mains and (ii) battery fault, charger fault and loss of output.

- Up to 5A current to load at 27.6V dc nominal regulated output.
- Charging capability to support 7 or 17Ah batteries.
- Electronic overload protection shuts down output until overload or short circuit is removed.
- Battery Monitor detects battery missing, low battery, short-circuit, reverse connection or circuit impedance (Ri) in excess of 300mΩ caused by connector or wiring corrosion.
- Battery charging circuit is energised only when a battery is correctly connected and the battery voltage is greater than 14V.
- No loss of output during automatic connection of battery to load on loss of mains.
- Deep discharge protection disconnects battery from load when battery voltage level falls below 21V.
- Internal diagnostic indicator LED (Orange).
- Fault indicator LED (Yellow) flashes on detection of output fault, battery fault, charger fault and mains failure.
- Mains indicator LED (Green) showing mains present Indicators check at start-up.

SPECIFICATION

Mains Input

Rated Voltage (Operational voltage)	110 – 240V ac (90 – 264V ac)
Frequency	50/60 Hz
Input current	< 2.0 Amps at full load
Inrush current	25A Max at 25 °C 110V ac for 10ms
Fuse	T3.15 A, 20 mm, 250V ac HRC

Output

Voltage at full load Mains power Battery standby	27.0 – 28.3V dc (27.6V nominal) 20.3 – 26.0V dc		
Ripple	<100 mV pk – pk max @ Rated Voltage		
Fuse Load Battery	F5.0 A F5.0 A		
Battery mode selected	2.1 Ah	7 Ah	17 Ah
Continuous Output Current (Imax A = Imax B)	5.0 A	5.0 A	5.0 A
Battery Capacity eg - PowerSonic model - Yuasa model - Interlogix model	2 x 2.1Ah 12V PS12021 NP2.1-12	2 x 7Ah 12V PS12070 NP7-12	2 x 17Ah 12V PS12170 NP17-12 BS131N
Battery Charging	Constant current bulk charging to 80% capacity within 24 hours Float charging to 100% within 48 hours Eco charging and check every 24 hours – (for up to 8 hours pulse charge dependent on temperature)		
Constant current charge	0.8A		
Low battery threshold voltage	23V		
Deep discharge protection	Threshold voltage – 21V		
Quiescent current – no load	< 30mA @ 27.6V		
Quiescent current – batt cut off	0mA @ 27.6V		

Mechanical

Product Reference	STX2405-MOD
Enclosure Dimensions w x h x d (mm)	156 x 145 x 60
Weight (kg)	0.66

Environmental

Temperature – Operating	-10 to +40°C (operating) 75% RH non-condensing
Temperature - Storage	-20 to +80°C (storage)

Connections and Signalling outputs

Load Output +/-	Screw terminals Voltage output to load
GEN PSU Fault (normally closed contact)	0.10A @ 60V dc 16Ω solid state relay contacts, volt free Open if Mains failed and battery voltage < 23V or fault PSU fault condition, (see below)
EPS Fault (normally closed contact)	0.10A @ 60V dc 16Ω solid state relay contacts, volt free Open if loss of mains > 10 seconds
Temperature sensor	Thermistor input from supplied battery terminal thermistor.
BATT +/-	Connection to back up battery using supplied battery lead

SIGNALLING AND DIAGNOSTICS**Fault Outputs**

EPS Fault	GEN Fault	Condition	Possible Cause	Action
CLOSED	CLOSED	Normal operation	Mains present Battery healthy	None
OPEN	CLOSED	Standby Mode	Mains lost Battery driving load	Investigate loss of mains
CLOSED	OPEN	Fault Present	Blown fuses Battery fault Internal fault	Investigate fault source using diagnostic LED Rectify fault where possible
OPEN	OPEN	PSU Shutdown	Mains lost Standby battery exhausted	Restore mains as soon as possible

LED Indication

YELLOW LED	Fault LED
GREEN LED	Mains supply On
DIAGNOSTICS	Diagnostic LED

Fault Diagnostic table – Front panel - User

Yellow LED Fault	Green LED Mains	Condition	Possible Cause	Action
OFF	ON	Normal operation	Mains present Battery healthy	None
FLASH CONTINUOUS	ON or OFF	Fault	Blown fuses Battery fault Internal fault	Contact service engineer
1 PULSE/S	OFF	Standby Mode	Mains lost Battery driving load	Investigate loss of mains

Fault Diagnostic table – Internal - Engineer

Orange LED Diagnostic	Green LED Mains	Condition	Possible Cause	Action
OFF	ON	Normal operation	Mains present Battery fully charged	None
	OFF	Standby Operation	Mains Lost. No faults present Battery driving load	Investigate loss of mains
FLASH CONTINUOUS	ON or OFF	No output	Output fuse blown Output overload Output short circuit	Check and replace output fuse Disconnect output load and test load
1 PULSE	ON	Battery Charging	No faults active Battery charging normally but < 90% of full charge	None
2 PULSES	ON	No Battery	Battery disconnected Battery fuse blown Battery heavily discharged	Check battery connections Check battery fuse Check battery condition Replace battery if aged
	OFF	Low Battery Volts	Standby Mode Battery almost discharged	Restore mains
3 PULSES	ON or OFF	Battery Fault	High impedance in battery connection Battery internal fault	Check battery connections for corrosion. Replace battery if aged
4 PULSES	ON or OFF	Charger Fault	Internal failure of battery charger	Return to manufacturer
5 PULSES	ON or OFF	Battery Temperature Probe Fault	Battery temperature monitor disconnected or damaged PSU running in Safe Mode	Check temperature sensor connections and condition of sensor. Replace if suspect

INSTALLATION

This unit is only suitable for installation as permanently connected equipment. The PSU is NOT SUITABLE for external installation.

This unit must be fed from a mains power source having a separate (approved) disconnect device and fitted with a fuse or other over-current protection device rated at 5A maximum. Ensure that the disconnect device used has appropriate earth fault protection to the applicable standard.

Where the PSU is used to provide power to a fire alarm circuit, the mains isolation and disconnect device should be provided solely for this purpose and be suitably marked "FIRE ALARM – DO NOT TURN OFF". All cabling should meet national and local fire system installation regulations, e.g. FP200 type cable for high integrity installations.

Where the PSU is used for other applications, it should be installed according to all relevant safety regulations applicable to that application.

Where the GEN PSU Fault and EPS Fault outputs are used, they should only be connected to circuits having voltages less than 60V dc.

Cable Sizing

- 1) Mains input cable must be to the applicable standard with a 5A or greater current capacity, i.e. 0.75 mm² nominal conductor area, having a minimum operating voltage of 300/500V ac.
- 2) The low voltage output cable must be sized to carry the rated load current to the devices connected to the PSU, at full 5 Amp load this should be 1.5 mm² CSA.
- 3) All cabling should be securely fastened in position.

Mounting the Module

- 4) Fix the module into chosen enclosure using 3 x fixing points as per Fig 1 (All fixings must be used). Ensure sufficient space for heat dissipation and adequate ventilation to avoid overheating of the unit or associated batteries.

Figure 1 – Fixing points

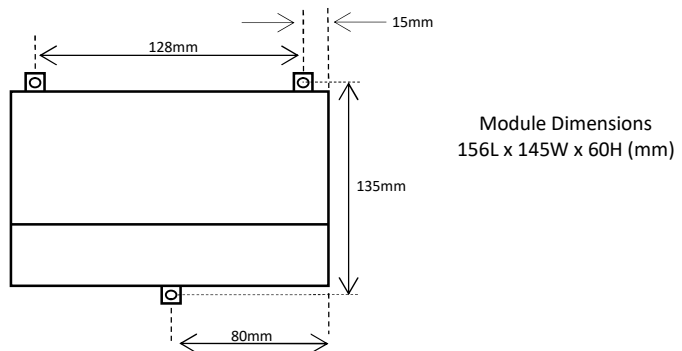

COMMISSIONING

Mains Power Up

- 1) With no external connections made to the PSU, connect the mains input wires to the terminal block, **ensuring that the mains isolator (disconnect device) is open**. Fasten wiring in place with cable tie to saddle. **Note: Equipment must be earthed.**
- 2) Apply mains input. Confirm that all LED indicators flash on briefly proving integrity of indicating circuits. Ensure that the green Mains LED then stays illuminated and that the yellow Fault LED flashes after approximately 3s (indicating a disconnected battery).
- 3) Disconnect the mains power.

Load Output and Remote Signalling

- 4) Connect the EPS and GEN PSU Fault outputs to the appropriate inputs of control equipment if remote fault monitoring is required.
- 5) Loop the load (output) wiring through the supplied ferrite EMC suppressor.

Figure 2 – Connections

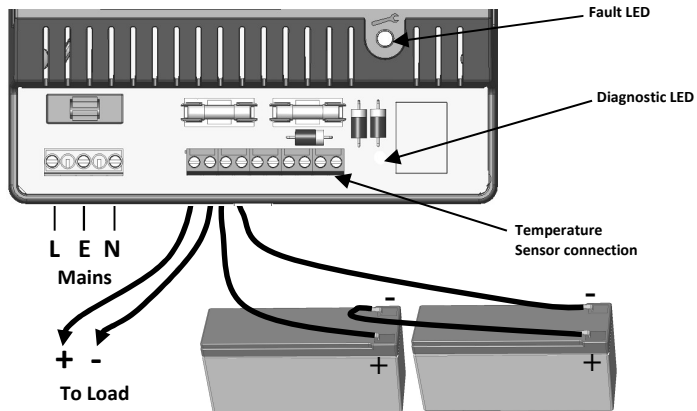

- 6) Re-apply mains. Verify that the green Mains LED illuminates and the yellow Fault LED flashes after approximately 3s (disconnected battery).
- 7) If connected, verify that the EPS Fault monitor shows a *closed* contact and the GEN PSU Fault monitor shows an *open* contact.
- 8) Perform a full functional test of system including full alarm condition.
- 9) Disconnect mains.

Figure 3 – Terminal labels

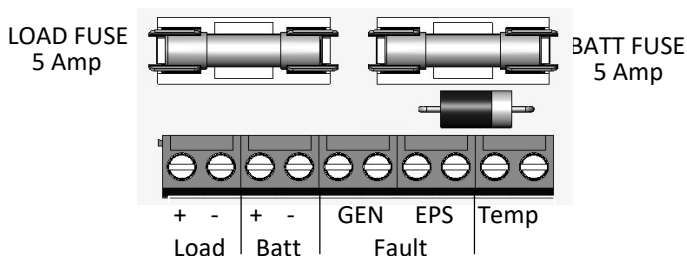

Standby Batteries

- 10) With mains *disconnected*, connect the two 12V standby batteries in series using the single cable provided. Connect the *negative* of one battery to the *positive* of the other. **DO NOT CONNECT** the other two battery terminals to each other.
- 11) Connect the free Positive and Negative terminals of the batteries to the PCB terminals Batt+ and Batt- using the cables provided. See Figure 2 and 3.
- 12) Connect the battery temperature sensor (two white wires) to the PCB terminals Temp Sense. See Figure 3. Wires can be connected either way around.
- 13) Re-apply mains and, after the LED indicators initial start-up flash, verify that the yellow Fault LED does not flash (battery connection detected). Verify that the remote PSU Fault monitor shows a *closed* contact.

- 14) Disconnect the mains power. Verify that the green Mains LED extinguishes and the yellows Fault LED starts to pulse (indicating that the PSU is running from its standby batteries).
- 15) If connected, verify that the EPS Fault monitor shows an *open* contact and the GEN PSU Fault monitor shows a *closed* contact.
- 16) Perform a full functional test of system including full alarm condition. Verify that the standby batteries can support the system load. Note: ensure batteries have sufficient charge.

Final

- 17) Reconnect the mains. Verify that the green Mains LED illuminates and the yellow Fault LED extinguishes.
- 18) If connected, verify that the EPS Fault monitor shows a *closed* contact and the GEN PSU Fault monitor shows a *closed* contact.

NOTE: Batteries must be connected before mains power is applied to enable the batteries to be utilised. When replacing batteries, re-connect new batteries and then cycle the mains power.

OPERATING INSTRUCTIONS

In the event of loss of mains, a battery fault or a GEN PSU fault, the corresponding Fault signal contacts will open.

If the output of the PSU fails, the cause of the failure should be investigated e.g. short circuit load, connection of a deeply discharged battery. The fault should be rectified before restoring power to the PSU. If any of the fuses require replacing, ensure the correct fuse rating and type is used.

MAINTENANCE

This unit is intended for use by Service Personnel only. There are NO USER SERVICEABLE parts inside.

There is no regular maintenance required of the PSU other than periodic testing, and replacement of the standby battery. ***Reference should be made to the battery manufacturer's documentation to determine typical/expected battery life with a view to periodic replacement of the battery.***

COMPLIANCE

This power supply unit meets the essential requirements of the following EU Directives:

EMC:	2014/30/EU
Low Voltage:	2014/35/EU
WEEE:	2012/19/EU
RoHS:	2011/65/EU



DISPOSAL OF PRODUCT AT END OF LIFE

This product falls within the scope of EU Directives 2012/19/EU Waste Electrical and Electronic Equipment (WEEE) and 2013/56/EC (Battery). At the end of life, the product must be separated from the domestic waste stream and disposed via an appropriate approved WEEE disposal route in accordance with all national and local regulations.

Before disposal of the product, any batteries must be removed, and disposed separately via an appropriate approved battery disposal route in accordance with all national and local regulations. Package used batteries safely for onward transport to your supplier, collection point or disposal facility.

**Caution: Risk of fire or explosion
if bare battery wires are allowed to touch.**

See Specification for battery type information. The battery is marked with the crossed out wheellie bin symbol, which may include lettering to indicate cadmium (Cd), lead (Pb), or mercury (Hg).

For more information see: www.recyclethis.info

*The packaging supplied with this product may be recycled.
Please dispose of packaging accordingly.*

Explanation of symbols: (Not all may apply)



Fault Indication



Shock Risk - isolate before attempting access



Certification Level



Mains Present



Protective Earth



Do not dispose of in unsorted waste

Specifications subject to change without notice